

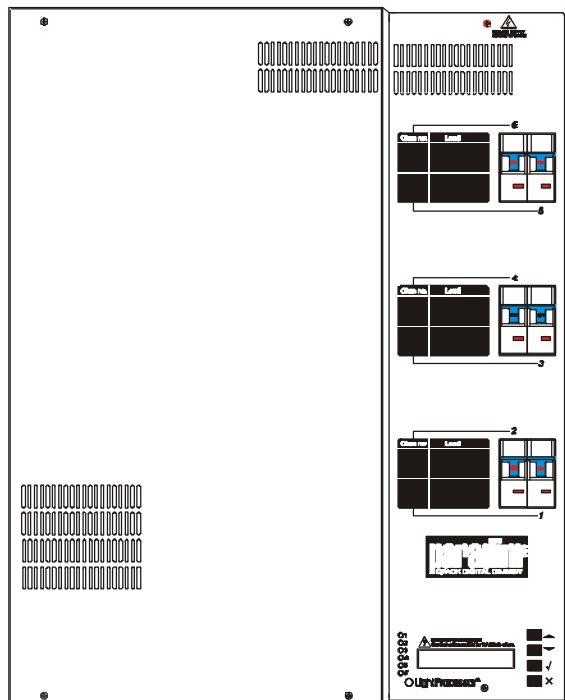

# INSTALLATION AND OPERATING MANUAL

Version 21, September, 2003, (all variants)

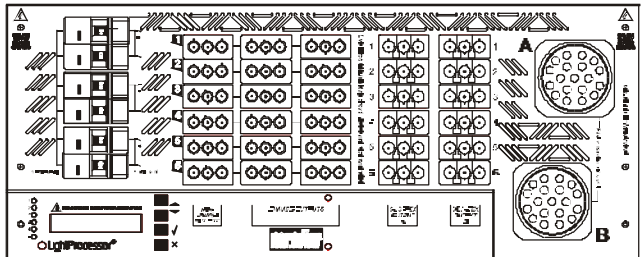

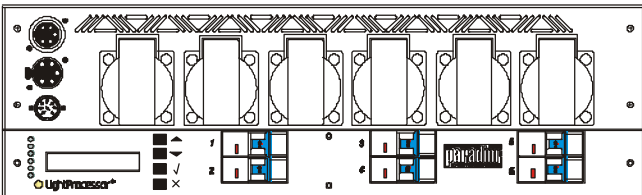
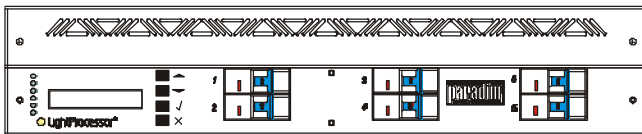

Thank you for buying a LightProcessor product. To obtain the best results, please read this instruction manual carefully. Further copies of this manual may be obtained from our website at [www.lightprocessor.com/paradimemanual/en](http://www.lightprocessor.com/paradimemanual/en)



Nous vous remercions d'avoir acheté un produit LightProcessor. Pour obtenir les meilleurs résultats, nous vous prions de bien vouloir lire attentivement ce manuel. Vous pouvez obtenir ce manuel en français de notre site internet à [www.lightprocessor.com/paradimemanual/fr](http://www.lightprocessor.com/paradimemanual/fr)



Wir bedanken uns für die Wahl eines LightProcessor-Produktes. Für eine reibungslose Bedienung lesen Sie sorgfältig dieses Handbuch. Dieses Handbuch in deutscher Sprache ist von unserem Website erhältlich. [www.lightprocessor.com/paradimemanual/de](http://www.lightprocessor.com/paradimemanual/de)



Le damos las gracias que Ud. ha comprado un producto de LightProcessor. Para los mejores resultados lea cuidadosamente este manual. Ud. puede obtener este manual en español de nuestro sitio internet a [www.lightprocessor.com/paradimemanual/es](http://www.lightprocessor.com/paradimemanual/es)



**Please be aware of the following warning notices and their meaning!**  
**Veillez faire attention aux avertissements suivants!**  
**Beachten Sie bitte die folgenden Warnungen !**  
**Desee cuenta de los siguientes avisos importantes!**



**CAUTION! RISK OF ELECTRIC SHOCK**  
**ATTENTION! RISQUE DE CHOC ELECTRIQUE**  
**ACHTUNG! GEFAHR EINES STROMSCHLAGES**  
**¡ATENCIÓN! PELIGRO DE SHOCK ELECTRICO**



**CAUTION! REFER TO INSTRUCTION MANUAL**  
**ATTENTION! REFEREZ-VOUS AU MODE D'EMPLOI**  
**ACHTUNG! BEACHTEN SIE BITTE DIE BEDIENUNGSANLEITUNG**  
**¡ATENCIÓN! REFERIRSE AL MANUAL DE INSTRUCCIONES**



**IT IS ESSENTIAL THAT YOU MAKE AN EARTH CONNECTION BEFORE CONNECTING THE DIMMER TO THE MAINS SUPPLY .**  
**IL EST INDISPENSABLE DE RACCORDER L'APPAREIL A LA TERRE AVANT D'ETABLIR LA CONNECTION AU SECTEUR.**  
**VOR ANSCHLUSS DES DIMMERS BITTE UNBEDINGT EINE ERDUNG DURCHFÜHREN.**  
**ALTA VOLTAJE. NECESITA ABSOLUTAMENTE UNA CONEXION CON TIERRA ANTES DE HACER LA CONEXION A LA RED.**

The material contained in this document is for information purposes only and is subject to change without notice. LightProcessor Limited assumes no responsibility for any errors or omissions that may appear in this manual.

Le contenu de cette documentation n'est donné qu'à titre indicatif et peut changer sans avis préalable. LightProcessor Limited n'accepte pas de responsabilité pour n'importe quelle erreur ni omission.

Die Informationen in diesem Handbuch sind unverbindlich gegeben und wir behalten uns das Recht vor, Änderungen zu machen. LightProcessor Limited akzeptiert für Fehler und Auslassungen keine Verantwortlichkeit.

El contenido de este documento es dado para su información solamente y está sujeto a cambios sin previo aviso. LightProcessor Limited aceptan ninguna responsabilidad para errores y omisiones.

## CONTENTS

	Page
<b>General Instructions</b>	I
<b>Installation Instructions</b>	
Quick set-up and install	I
Mounting Rackmount Models in a Standard 19 Inch Rack	II
Mounting Wallmount Models to the Wall	II
Changing the supply voltage	III
Connecting the supply	IV
Connecting the outputs	V
Changing the supply input phase order	VI
<b>User Instructions</b>	
Connecting the control inputs	1
Front panel controls and features	2
Cooling and DMX fan control	2
Using the dimmer without a control desk	3
Using the Paradime Patchpack	3
Using the dimmer with remote controls	4
Control Modes	5
Menu system and user options	6
Diagram - menu structure	11
<b>Reference Section</b>	
Maintenance	12
System Messages	13
Specification	14
Spares List	15
Warranty Statement, Repairs Procedures	16

## ACCESSORIES PACKED WITH THE PRODUCT

### Rackmount Models

Instruction manual  
Front and rear mounting cheek set  
6 x 0.4m patch cables (patchpack only)  
Single phase links (10A models only - packed inside the dimmer)

### Wallmount Models

Instruction manual  
Single phase links (10A models only - packed inside the dimmer)

## OPTIONAL EXTRAS

### Rackmount Models

Service Plates, see page V  
Wallplates, see page 4  
Additional Patch Leads, see page 13  
DMX/Analogue Cables, see page 13

### Wallmount Models

Wallplates, see page 4  
XLR/DIN Input Plate, see page 1

## GENERAL INSTRUCTIONS

Read the instructions in this handbook carefully, as they give important information regarding safety during installation and use. Be sure to keep this manual with the product for ease of future reference. If the product is sold or given to another operator, make certain that they also receive the manual.

- After removing the packaging, check that the product is not damaged in any way. If in doubt, do not use it. Contact an authorised LightProcessor distributor.
- Packaging material (plastic bags, etc.) must not be left within the reach of children, as it can be dangerous.
- The product must only be operated by adults. Do not allow children to tamper or play with it.
- This product must be installed by a qualified electrician.

### NEVER USE THE PRODUCT UNDER THE FOLLOWING CONDITIONS:-

- In places subject to excessive humidity
- In places subject to vibrations or bumps
- In places with an ambient temperature in excess of 30°C or less than 0°C
- Protect the product from excessive dryness or humidity (ideal conditions are between 35% and 80%)
- Do not dismantle or modify the product
- Ensure that no liquids or metal objects enter the product
- Should any liquid be spilled on the product, disconnect the power supply immediately
- In the event of serious operating problems stop using the product immediately and either contact the nearest LightProcessor distributor for assistance or contact the manufacturer directly.
- Never try to repair the product yourself. Repairs or modification could cause damage or faulty operation. Contact your nearest LightProcessor dealer.
- When carrying out any work, always comply (particularly regarding safety) with all regulations in force in the country in which the product is being used.

## QUICK SET-UP AND INSTALL

1. Unpack the Product. (Ensure you do not throw away any accessories packed separately in the box.)
2. Rack models:-  
Remove the front panel screws, Fig. 3, page III. Slide the chassis forward, taking care to release the earth strap on the right hand side and pull it out completely from the lid section.  
Wall models:-  
Remove the front panel screws. Remove both panels, taking care to release the earth straps, Fig. 1, page II.
3. Rack models:-  
Mount the lid section into the rack using both front and rear rack support brackets. Ensure adequate ventilation.  
Wall models:-  
Secure the chassis to the wall. Ensure adequate ventilation.
4. If you intend to connect the unit to a single phase supply, fit the single phase input links provided, (10A per channel units only) Fig. 6, page IV.
5. Check that the mains input voltage selector links are correctly set for the supply to be connected (115/230V). Refer to page III, figs. 4 and 5.
6. Connect the power input and output load cables.
7. Rack models:-  
Slide the dimmer chassis into the lid section now fitted into the rack. Ensure that the earth strap is reconnected. Replace the front panel screws. Connect the signal input cables, figs. 10-12, page 2.  
Wall models:-  
Connect the signal cables.  
Replace the front panels and screws, ensuring that the earth straps are re-connected.
8. Apply power.
9. Set the required input option (DMX+ANALOG is the factory setting).
10. Please take the time to read the full instruction manual which contains information on:-
  - a) The safe use of the product
  - b) Setting up the special features
  - c) Adding accessories
  - d) Routine maintenance

## MOUNTING INTO A STANDARD 19 INCH RACK CABINET

This product is designed to be mounted horizontally using both the front and rear supports provided. Failure to fit both front and rear supports will reduce product life and void the warranty.

1. Remove the front panel screws, as shown in Fig. 3 on page III, open the unit, detach the earth cable and remove the dimmer chassis from the lid section.
2. Fit both the front supports using the 8mm. M4 screws provided to the lid section of the unit.
3. Measure the distance between the front face of the front rack support and the rear face of the rear rack cabinet rail.
4. Offer the rear rack support brackets up to the lid section. Move the rear supports until the distance between the front and rear support is similar to the distance previously measured in the rack cabinet. Mark two holes in the rear support bracket that best align with the slots in the lid.
5. Insert M6 cage nuts supplied into the marked holes.
6. Line up and fix the rear support brackets into the rear of the rack.
7. Fix the lid section into position in the 19" rack cabinet using the front supports.
8. Secure the lid section from the inside to each of the rear support brackets using the M6 10mm.bolts supplied.
9. Slide the chassis partially back into the lid section.
10. Proceed to page III.

## MOUNTING WALLMOUNT MODELS TO THE WALL

This product is designed to be mounted vertically in an upright attitude. Failure to mount correctly will prevent the ventilation system from functioning correctly and may lead to operational problems and will void the warranty.

1. Open the unit by removing the six screws securing the two front cover plates. Release the earth strap from each cover plate, noting the order of lockwashers, connector and nut etc.
2. Three fixing points are provided, as shown in fig. 2 below. Drill the wall and fit suitable screw anchors at these points and insert 1½" No. 10 (40 x 4mm.) roundhead woodscrews into the two upper screw anchors, leaving a 3mm. gap between the heads of the screws and the wall.
3. Hang the Paradime on the two screws, ensuring that the slots have engaged behind both screw heads. Tighten down the screws, so that the Paradime cannot be moved and insert the third screw.
4. Proceed to page III.

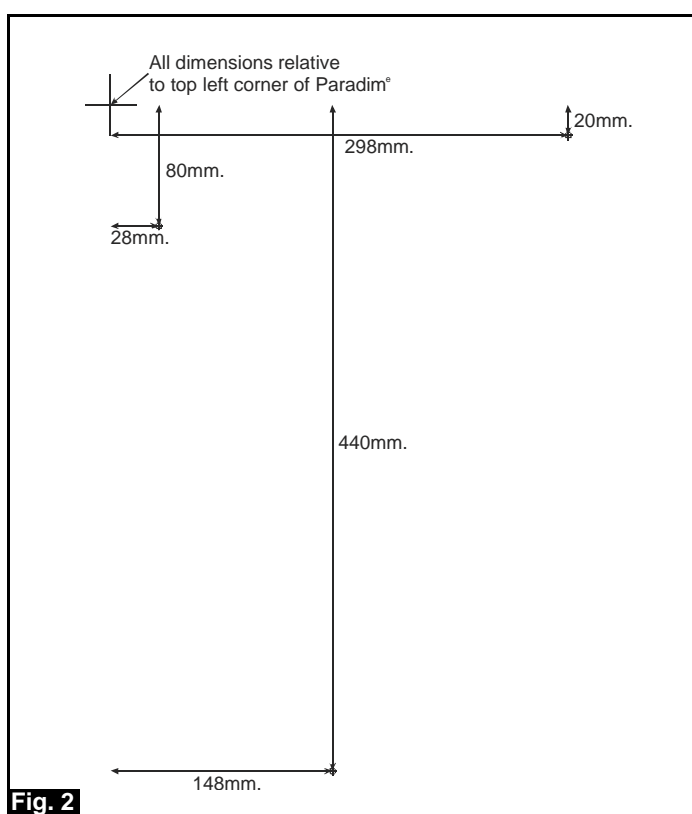
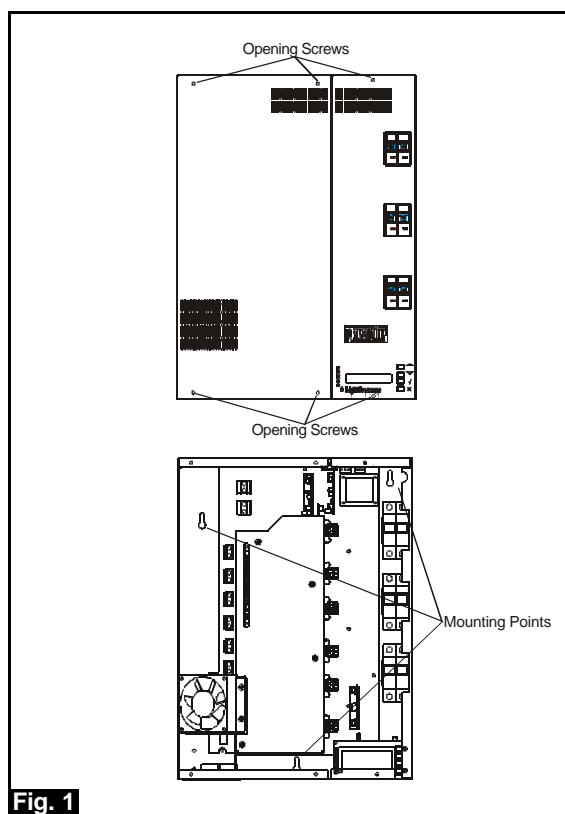

## CHANGING THE DIMMER FOR USE ON A DIFFERENT POWER SUPPLY VOLTAGE

The Paradime is able to operate on either 115V or 230V AC supplies. The internal power supply links must be altered, if appropriate, from the factory-set option. Disconnect and isolate the power supply from the dimmer.

### Rackmount:-

The supply links can be seen on the near right hand corner of the main printed circuit board. Remove the existing links and replace as shown in figs. 4A and 4B below.

Change the electronics protection fuse to the correct type and value for the chosen operating voltage, as shown below.

### Wallmount:-

The supply links can be seen in the top right corner adjacent to the transformer and electronics control fuse. Change the supply links as shown in figs. 5A and 5B.

Change the electronics protection fuse to the correct type and value for the chosen operating voltage, as shown in the table below.

Supply Voltage	Fuse type/value
115V	200mA (T) Anti-surge 5mm. x 20mm., glass
230V	100mA (T) Anti-surge 5mm. x 20mm., glass

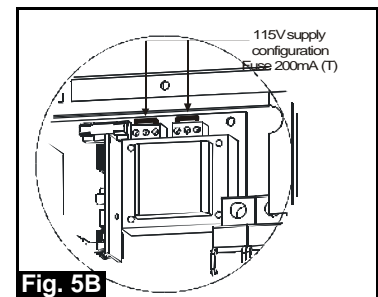
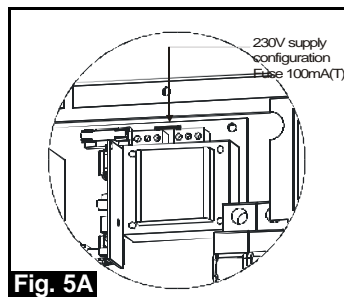
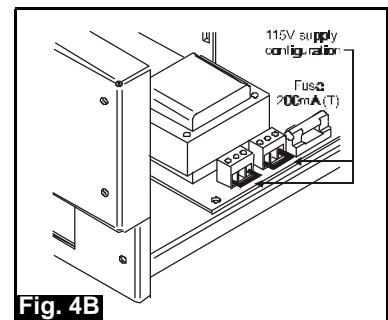
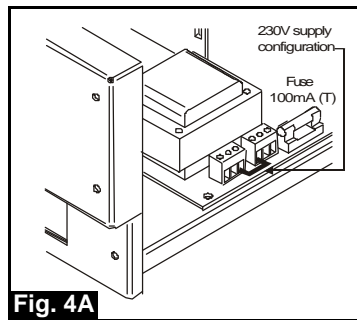
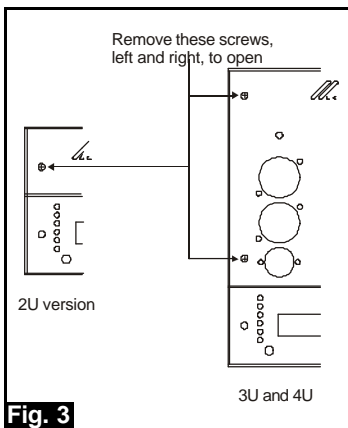

## CONNECTING THE SUPPLY

### SUPPLY INPUT WIRING - (STAR CONFIGURATION MODELS ONLY)

The dimmer is designed to operate on the following power supplies. See figs. 6 and 7.

#### 6 x 10 Amp models:

230V AC or 115V AC Single or Three phase & Neutral  
Maximum input current 60Amps one phase.  
Maximum input current 20Amps per phase.

#### 6 x 16 Amp models:

230V AC or 115V AC Three phase & Neutral  
Maximum input current 32Amps per phase.

#### 6 x 20 Amp models:

230V AC or 115V AC Three phase & Neutral  
Maximum input current 40 Amps per phase.

#### 3 x 25 Amp models:

230V AC or 115V AC Three phase & Neutral  
Maximum input current 25Amps per phase.

Ensure a mains power input cable of sufficient cross-section is used.

The input cable should be passed through a suitable cable restraining gland fitted in the 32mm. hole in the rear panel service plate (or in the side of a wall-mount Paradime). Draw in the input and output cables. Make connections as shown below.

Secure the earth conductor to the earth block:

#### For single phase supplies:

Where the Paradime is to be used single phase, the single incoming live conductor must be routed to the other two phase inputs using the supplied single-phase links (packed inside the dimmer). Fit the links provided to link terminal P1 to P2 and P2 to P3. Connect the live phase conductor to terminal P2. Connect the neutral conductor to terminal N1.

#### For three phase & neutral

**ENSURE THERE ARE NO SINGLE PHASE LINKS INSTALLED. IF THE PARADIME IS NEW, REMOVE THE BAG CONTAINING THE SINGLE PHASE LINKS FROM WITHIN THE ENCLOSURE.**

Connect the three Live phase conductors to terminals P1, P2 and P3.  
Connect the neutral conductor to terminal N1.

Tighten the gland around the cable.

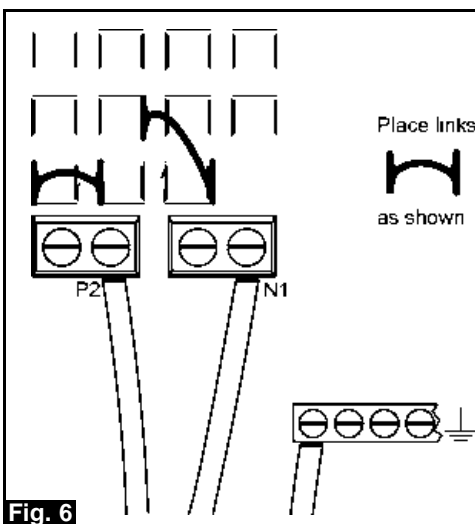

Fig. 6  
Single Phase Connection

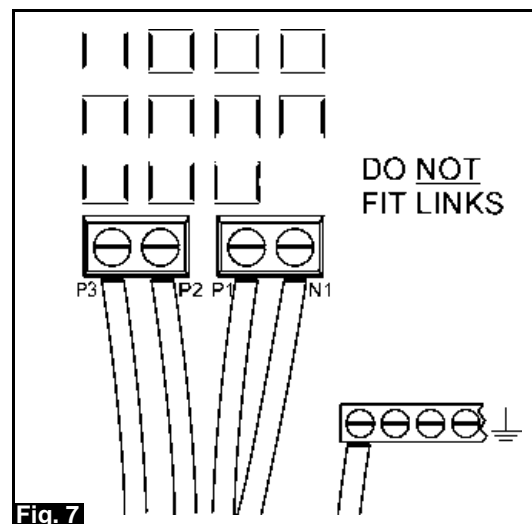

Fig. 7  
Three Phase Star Connection



## CONNECTING THE OUTPUTS

### Rackmount:

(Hardwired Versions)

The standard rear service panel is provided with a series of 20mm. holes. The complete panel may be removed to allow more space while connections are made.

Distribute the output cables via one or more cable restraining glands. It is essential that the live and neutral pair for each output passes through the same gland. Secure the earth conductors to the earth block. Connect the live and neutral conductors to output terminal blocks marked for each of the six channels.

Tighten the cable glands and ensure that the cables cannot be strained.

(Socket Versions)





Various international output socket types are available. Consult your dealer or the LightProcessor website for further details. Outputs may be made via the output terminal blocks inside the rear of the Paradime as well as via the front-panel sockets.

(Patchpack)

The Paradime Patchpack offers six direct non-dimming patches and twelve dimming patches to two 19-pin output connectors. The Patchpack can be used stand-alone or built into larger touring systems. See page 3.

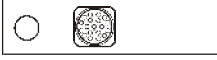
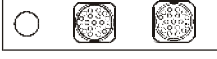
### SERVICE PANEL OUTPUT OPTIONS

Additional service panels, either blank or pre-fitted and wired to multi-pole connectors, are available as accessories for fitting to all models of the dimmer.

SERVICE PLATE TYPES			
Connector Type	Connectors	Part Number	
Blank	0	MPARADIM/B	
19-pin Ceep/Socapex	1	PAR/S/SOC	
19-pin Ceep/Socapex	2	PAR/D/SOC	
16-pin Wieland/Harting	1	PAR/S/HART	
16-pin Wieland/Harting	2	PAR/D/HART	
Wieland Hotpatch	12	PAR/HOT	

### Wallmount:

(Hardwired Versions)

The left side-panel is provided with a series of 20mm. holes and there is an additional access plate on the top face of the enclosure.

Distribute the output cables via one or more cable restraining glands. It is essential that the live and neutral pair for each output passes through the same gland. Secure the earth conductors to the earth block. Connect the live and neutral conductors to output terminal blocks marked for each of the six channels.

(Socket Versions)

Variants are available with 12 x UK 15A socket, 6 x double Schuko socket (special order), 6 x double French socket (special order). Outputs may be made via the output terminal blocks inside the rear of the Paradime as well as via the front-panel sockets.

Tighten the cable glands and ensure that the cables cannot be strained.

## CHANGING THE SUPPLY INPUT PHASE ORDER AND FREQUENCY

### FACTORY DEFAULTS

The factory defaults are automatic phase detection and automatic frequency detection.

### AUTO FUNCTION

Paradimes, shipped from the factory with version 16 software or later, are supplied with two phase detection modules; this will enable the unit to auto-detect the phase order of an incoming three-phase supply or the single phase and requires no software set-up by the user. Note that the Paradime is designed for single phase and three phase systems and cannot be run from two phases.

### INSTALLER HARDWARE LOCK

Users may be prevented from clearing error messages without reference to a qualified technician by the hardware 'lock'. In order to remove the 'lock' it is necessary to remove the hardware link situated behind the display board. Unless you want the user to be able to clear error messages from the front panel, ensure the link is in place after making any changes. See figs. 8 and 9 below. Note that the hardware link is not fitted in the Patchpack variants.

### MANUAL SET-UP

The phase order may be set manually, if desired. NOTE: The hardware lock must be removed to allow this. (See 'Installer hardware lock' above).

Press and release the 'down' key  $\nabla$  until the display shows 4 SET SUPPLY?

Note that the numbers on the left of the screen identify the menu number. These are useful when helping users to find their way around the menus and are references to the menu tree diagram on page 9 of this manual.

Press the  $\checkmark$  - the display will show  
41 SET PHASES?

Press the  $\checkmark$  - the display will show  
411 SET ORDER [auto] (factory setting).

Pressing the up or down arrow keys will change the setting within the square brackets on the display. Subsequent presses will display the different settings available, these are:-

[111] Single Phase  
[123] 3 Phases connected in the order 1,2,3  
[132] 3 Phases connected in the order 1,3,2  
[aut] Auto Phase order detection

Change to the desired option and press  $\checkmark$  to select and memorise the setting. The display will momentarily show STORED OK.

Automatic phase detection will only be functional if a second phase-detect module is fitted. In the event that it has been removed, next time the unit is powered up, the Paradime will detect its absence and will select the last setting used when the second phase-detect module was present. If single phase input to a 16A, 20A or 25A pack is detected, the Paradime will operate normally but note that it should be protected by a 63A single phase circuit breaker to restrict the maximum input current to 63A.

When the display shows 411 SET ORDER [ ], pressing the  $\times$  key takes you to 41. Press  $\wedge$  to get to menu 42, SET FREQ? Press  $\checkmark$  to get to 421 FREQ and then use the  $\wedge/\nabla$  keys to select [50Hz], [60Hz] or [auto].

If the Paradime is to be supplied from a generator, using the [auto] frequency setting will avoid problems in the event that the output frequency from the generator is not constant.

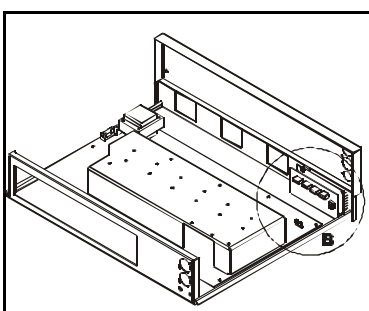

Fig. 8A

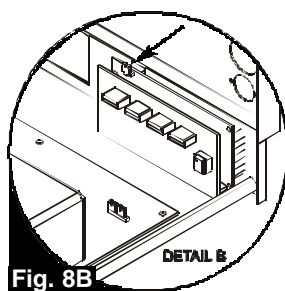

Fig. 8B

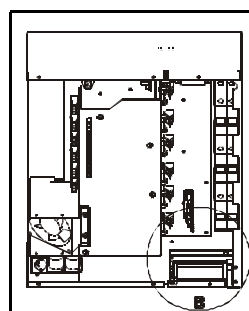

Fig. 9A

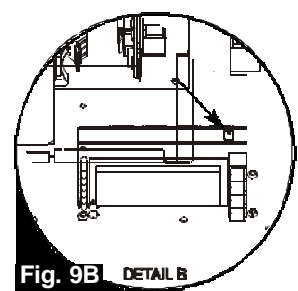

Fig. 9B

## CONNECTING THE CONTROL INPUTS

### ALL RACKMOUNT VERSIONS AND WALLMOUNT VERSIONS FITTED WITH INPUT SOCKET PANEL OPTION

#### •DMX

DMX connections are made via a 5-pin XLR plug, wired according to the USITT DMX512 1990 standard, as in fig. 10. The DMX output is unbuffered.

If the dimmer is the last piece of equipment in the signal chain, the DMX line should be terminated to ensure reliable signal reception. This is done by plugging in an XLR plug fitted with a 120 ohm resistor into the DMX output socket. See fig. 11.

Note that the appropriate protocol must be selected in software: see menu 51.

#### •ANALOGUE

Analogue control of each channel is via the 8-pin locking DIN plug wired as shown in the diagram. The control voltage is 0 volts (0% output) to approx. +10 volts DC (100% output). The dimmer provides a nominal 16V DC 'phantom' output supply @ 100mA maximum. See figs. 12A and 12B

Check the user manual of any equipment you intend to connect to the analogue input if you are unsure of the phantom supply polarity and specification.

Note that the appropriate protocol must be selected in software: see menu 51.

### WALLMOUNT - STANDARD WITH HARDWIRED CONNECTIONS

When making connections note that the black headers may be unplugged from the circuit board to allow for easier cable termination outside of the unit. See Fig. 13.

The termination jumper should be placed in the OFF position, unless the Paradime is the last device in the DMX chain.

An optional XLR/DIN plug-in connector set is available as an alternative to hardwired connections. These connectors plug in to the white headers which are exposed when the terminal connector circuit board is removed. For this reason hardwired connections cannot be used when the socket option is fitted.

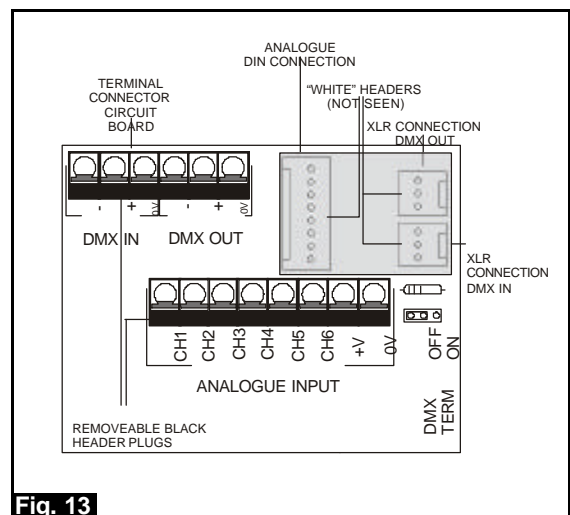
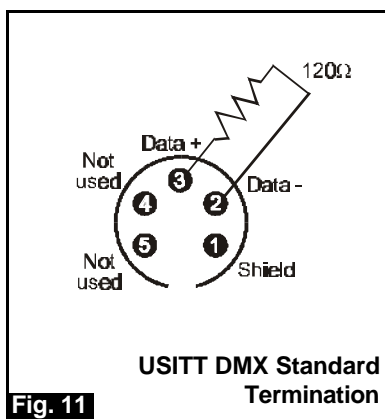
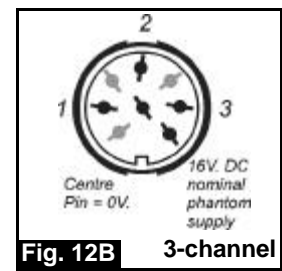
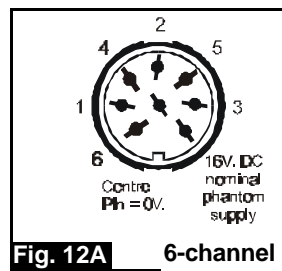
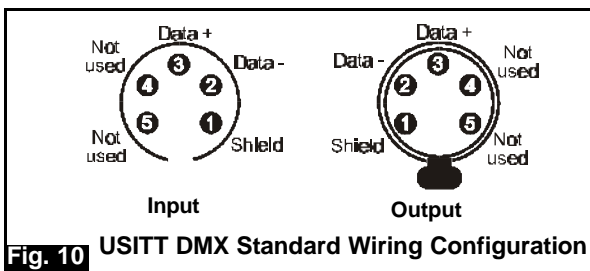

## FRONT PANEL CONTROLS AND FEATURES

Finalise the installation by re-connecting the earth cable, replacing the front panel(s) and re-fitting the securing screws.

### POWER UP ROUTINE

When power is applied to the unit, a self-test is performed. The LCD text display shows SELF TEST. When the self test is passed, the display will show either PARADIME READY (followed by a scrolling message) if the menus are locked, or 'DMX START nnn' if the menus are unlocked. If a valid DMX signal is being received, OK will be displayed on the far right hand side of the display.

### DISPLAY

Version 21 software Paradimes (and later) are identifiable by their backlit, blue display. The display will illuminate when menu buttons are pressed and will switch off after a short period when no buttons are pressed.

### SETTING / CHANGING FEATURES

All the features of the dimmer are set using the four push-buttons in conjunction with instructions and options shown in the LCD display. All features are accessed through menu choices. The complete menu structure can be followed on the diagram on page 9 of this manual. Each individual menu screen has an exclusive reference number to guide you through the process.

### SOFTWARE VERSION

The software version may be determined by reference to Menu 89 READ SERIAL?

### MENU - USER LOCKS

If your button presses are ignored, it may be because the menus have been 'locked' to prevent accidental changes being made. The menus must be 'unlocked' before changes can be made and if required, re-locked again afterwards. Menu locking is controlled by the 87 MENU ACCESS function within Menu 8 READ INFO?

### MENU - INSTALLER LOCKS

Certain items may be protected by an internal hardware 'lock' as shown in the diagram on page 10. These items should not normally need to be changed and you should contact your installer/supplier before attempting to do so. Note that these locks do not apply to Patchpack models.

### CLEARING LOCKS

See page 11 for details of error messages, their causes and remedies.

## COOLING AND DMX FAN CONTROL

The Paradime's fan cooling is electronically controlled by the microprocessor with override from a hardware thermostat. Exceptionally, users may wish to take control of the fan's operation by allocating a supplementary DMX channel to the fan.

(a) Normal use. At the lower temperature threshold, whether or not the fan puff is enabled (see menu 71), the fan will start to run constantly (or will cease to run if the pack is in a cooling cycle).

(b) Where DMX control of the fan is used (see menu 12), that threshold is raised approximately 10°. This mode is used during 'short burst' applications only, where low ambient noise levels must be maintained. Its use will reduce the duty cycle of the unit.

In either of the above operating modes, if the temperature exceeds the upper threshold, the hardware override will operate, all channels are disabled and an 'Over Temperature' error message is displayed. Users should contact their dealer/installer for assistance with clearing the error: installers should refer to page III of the installation instructions.

### FAN PUFF FEATURE

The fan 'puff' may be switched on where required. See menu 71.

## USING THE PARADIME WITHOUT A CONTROL DESK

In circumstances where there is no control desk available, the dimmer may be used to provide animated output or a selection of user-programmed scenes. Up to eight scenes containing individual levels for each channel may be 'captured' or recorded, held in memory and 'replayed'. Each scene is either 'captured' from the DMX or analogue input or created by setting the preheat level on each channel.

There are also nine chase sequence programmes available at ten different speeds programmed into the dimmer. For example,

PROG 10 = Chase pattern 1 @ speed 0 (fastest)  
 PROG 29 = Chase pattern 2 @ Speed 9 (slowest)

Preheat is set in menu 21.

Scenes are captured (recorded) in menu 32.

Scenes and chase programmes are chosen and replayed from menu 31.

The dimmer can also be set to replay a scene or chase programme in the absence of a DMX signal at power-up. This will start immediately the power is applied, without user intervention. The chosen scene or chase programme is selected in menu 36: the dimmer must be set for use with the DMX input in menu 51 (an actual DMX signal is not required). Note that, when a valid DMX signal IS connected, the chosen scene or chase programme will be disabled until the DMX signal is removed.

## USING THE PARADIME PATCHPACK

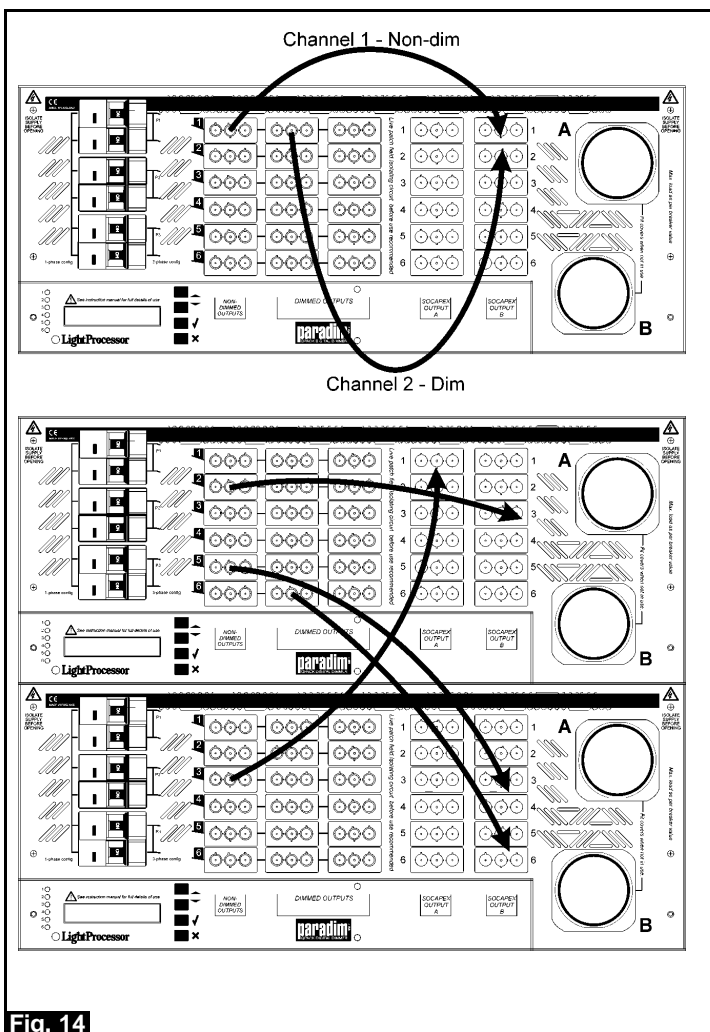

Fig. 14

**Dim and non-dim outputs may be used simultaneously.**

Example:

Channel 1. Constant live feed for motors  
 Channel 2. Dimmed feed for lamps.

Both are protected by circuit breaker 1 (in total 10A).

**Multiple packs may be cross-patched**

## USING THE PARADIME WITH REMOTE CONTROLS

The dimmer can be instructed to replay any of the eight captured scenes or nine chase programs from one or more remote low voltage control panels. The analogue input connector is used to access six remote 'preset' scenes or program chases. Each preset is 'mapped' to any one of the eight scenes or nine chases.

Depending on the type of remote panel or interface connected, any number of the presets may be exclusively selected or mixed together.

The remote functions may be selected by routing back the dimmer phantom output into the six input channels by push buttons, sliders, relay contacts, motion detectors or similar devices. Eight-core cable should be used, 7/0.2mm. (0.22mm<sup>2</sup>), (CAT5) or similar.

The scenes to be accessed from the remote device must first be 'recorded'.

Either

a) capture the current input to the dimmer from an analogue or DMX source (Menu 3 - Set Scenes, Menu 32 - Record)

or

b) set each channel, using the preheat control to construct a 'scene' of all six channels (Menu 21 - Set Preheat, then go to Menu 3 - Set Scenes, Menu 32 - Record) to 'record'.

Change the preheat settings, as required, for the next scene to be 'recorded'. When all the required scenes have been recorded, return all preheat levels to zero.

or

c) use a WP6 wallplate with the Paradime menu 321 GET SCENE [ n ] set to 'REMOTE PROGRAM'. See 'Remote programming and editing' on page 5.

Note: You may wish to program one of the scenes as an 'OFF' selection; most people choose to use scene 6 for this purpose.

Each scene may be set to fade in and out, when selected, by programming a fade time individually to each scene (Menu 3 - Set Scenes, Menu 35 - Set Fade Times)

The six inputs are mapped by default as 1-1, 2-2, 3-3, 4-4, 5-5, 6-6 but may be re-mapped as required, (Menu 3 - Set Scenes, Menu 34 - Map Inputs). Each of the six inputs is selected in turn and a scene (numbered 1-8) or a chase program (numbered 10-99) is chosen for each input.

Scene levels may be reviewed in menu 85, SCENE LEVELS.

The input and remote control panel type are set in menu 51. In the example shown in fig.15 this will be WP6.

Fig. 16 shows a WP9 remote control panel.

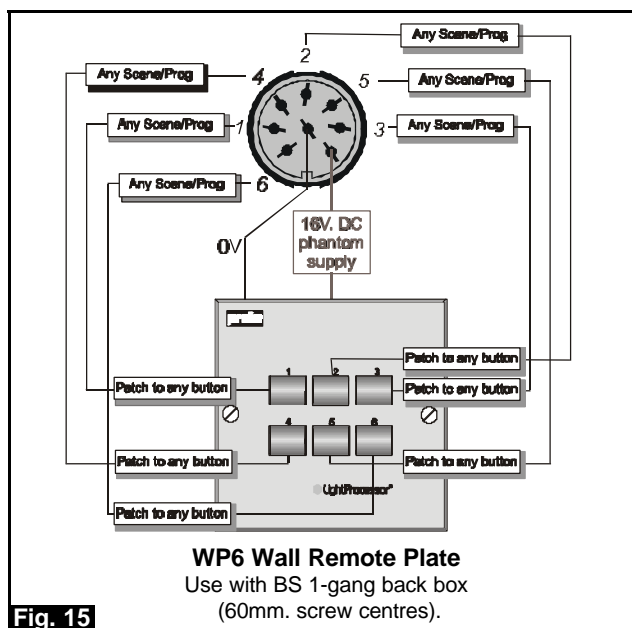

**Fig. 15**

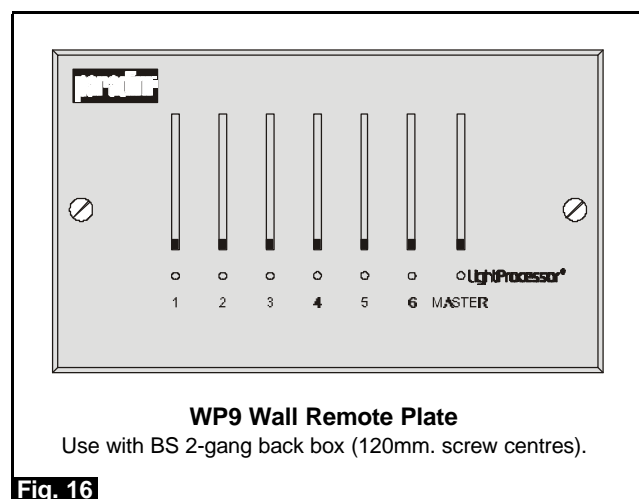

**Fig. 16**

## CONTROL MODES

A range of modes exists to allow control by various types of input signal, to establish rules of precedence where there are multiple inputs and to allow the connection of remote input devices. The selection of these modes is dealt with in menu 51 but their use is described here.

- 1. DMX only.** Only the DMX input is active. The analogue input is ignored.
- 2. Analog only.** Only the analogue input is active. The DMX input is ignored.
- 3. DMX+Analog.** DMX and analogue inputs are mixed on an HTP basis.
- 4. WP9 + DMX.** Six 0-10V inputs have level control over six scenes. Any or all of the scenes may be mixed on an HTP basis.
- 5. WP6 + DMX.** Latching scene control input for use with WP6 six-button remote panel or similar device. Levels from scenes selected by the WP6 mix with DMX on an HTP basis.
- 6. WP6+CONT.** A seventh DMX channel is used to establish the precedence of inputs from a WP6 and a DMX device. At the lower end of the slider range only the input from the WP6 is output and any input from the DMX source is ignored. In the middle of the slider range the input from the last source used is locked in the outputs (and is written to scene memory 7) and input from the other source is ignored. At the top of the slider range the output is determined by input from the DMX source. When moving from low to high, the 'locked' output is replaced by the current output from the DMX device. When moving from high to low, the 'locked' output remains current until a scene is selected on the WP6. See page 6 for setting the address of the seventh (auxiliary) DMX channel.
- 7. DMX/ANALOG.** A DMX signal will take precedence over any analogue signal being received and the analogue input is ignored. If DMX is not present or is lost, the analogue input signal is output. Note that, to use this mode, you will need to set the DMX FAIL response accordingly (normally ALL OFF) in menu 33.
- 8. WP6M** A WP6 or similar device may be used to select four scenes and also allow up/down adjustment when the Paradime input is set to WP6M in menu 51. The functions of the buttons are shown in Fig. 17 below. Pressing buttons 1, 2, 4 or 5 recalls the scenes allocated to memories 1, 2, 3 and four in menu 34. Buttons 3 and 6 gradually increase/decrease the level of of the channels until they reach 100% or 0. The original scene may be re-instated by pressing the appropriate scene button. Only those channels with levels greater than zero respond to the 'scene channels up' and 'scene channels down' buttons.

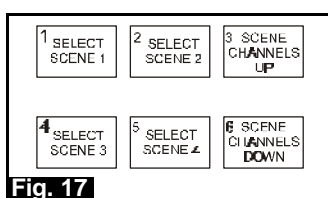

Fig. 17

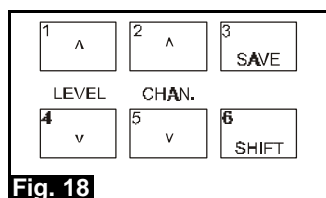

Fig. 18

### REMOTE PROGRAMMING AND EDITING

Scenes may be programmed or edited into the Paradime's memories from a WP6 or other similar analogue input device, when the Paradime is in remote mode. Remote mode 'R' is accessed using menu 321 GET SCENE and is found below scene 8 as you scroll down the list of scenes. Press ✓ and the display will show 'REMOTE PROGRAM'.

With the Paradime in remote mode an attached WP6 may be used to program scenes. Note the functions of the WP6 buttons in the Fig. 18. When you enter remote mode, scene 6 is active for editing, channel 1 is the current channel and the level output is the currently stored level.

At this point you may:-

- use buttons 1 and 4 to vary the level of channel 1 of scene 6.
- use buttons 2 and 5 to move through the channels of scene 6, prior to adjusting a level using buttons 1 and 4.
- use button 3 to save the current setting of scene 6.
- use button 6 as a shift key and hold it pressed while pressing one of the other buttons 1-5, to select one of the scenes 1-5. If you have not previously pressed button 3 to save any earlier scene programming, that programming will be lost. Once the SHIFT key has been used, access to scene 6 is only available by exiting and re-entering the remote programming mode.

Where you use some other type of analogue device, such as a small desk, the function of buttons 1-6 will equate to channels 1-6 on the desk. Note that all inputs in the remote programming mode are momentary.

## MENU SYSTEM AND USER OPTIONS

In all menus...

^ and v change the option in the display

✓ confirms a selection (YES), (ENTER)

✗ rejects a selection (NO) and takes no action (ESCAPE)

### 1 SET DMX ADDR?

If you intend to use DMX512 as the control protocol, you must set a start address.

Press ✓.

^v to select the attribute to change and press ✓.

#### 11 START ADDRS?

##### 111 START [001]

Default = 001.

^v to desired start channel and press ✓. ⇒ STORED OK

#### 12 AUX ADDRS?

The auxiliary channel allows control of the fan operation; see page 2. However, if the input in menu 51 has been set to WP6+CONT, the seventh channel no longer controls the fan but is used to move between WP6 control and DMX control as described on page 5.

##### 121 AUXdmx [nnn]

Default = off

^v to desired start channel and press ✓. ⇒ STORED OK



### 2 SET CHANNELS?

You may set the following attributes for each channel. Channel numbers are always expressed as channels 1-6 (or in some cases A for All channels) of this Dimmer pack and do not refer to DMX addresses.

Press ✓.

^v to select the attribute to change and press ✓.

#### 21 SET PREHEAT?

Set preheats to enhance lamp performance. Set a level where the lamp filaments just glow.

##### 211 CHANNEL [n]

^v to select channel (or All option [A]) and press ✓.

##### 2111 LEVEL [000]

Default = 0.

^v to desired level and press ✓. ⇒ STORED OK

#### 22 SET MAX OUT?

You may set the maximum output level for each channel. Thus if a channel is set to 50%, full slider travel on the control desk will be needed to bring the channel to 50%.

##### 221 CHANNEL [n]

^v to select channel (or All option [A]) and press ✓.

##### 2211 LEVEL [nnn]

Default = 255 (full)

^v to desired level and press ✓. ⇒ STORED OK

#### 23 SET CURVES?

Choose from: Linear, Square, Switch. Square law curve will provide a more accurate relationship between lamp brightness and control desk slider position, when using incandescent lamps.

Note that switch is specifically not a curve! It allows a switch only between full-on (at DMX 120) and full-off (at DMX 40) and is used where the connected load may be damaged if dimmed.

##### 231 CHANNEL [n]

^v to select channel (or All option [A]) and press ✓.

##### 2311 CURVE [LIN]

Default = Linear

^v to select curve and press ✓. ⇒ STORED OK



## MENU SYSTEM AND USER OPTIONS - cont'd

### 24 SET FADE?

Setting a fade time to a channel will slow down any level change received at the input. This enables smooth fade effects from simple switched inputs or may be used to protect the dimmer load from instantaneous level changes. Selected fade time applies to both fade in and fade out. NOTE: In this menu the fade time is applied to an individual channel and not a complete scene as in menu 35.

#### 241 CHANNEL [n]

↖/↗ to select channel and press ✓.

#### 2411 TIME [n]

Default = 1 (minimum).

↖/↗ to set fade time and press ✓.

Available fade times are approximately 0, 1.2, 3, 4, 7, 133, 165, 220, 330 seconds.

### 3 SET SCENES?

The user may program a total of eight scenes, 1-8, by recording the current dimmer pack output. Dimmer output can be achieved by recording incoming DMX/analogue signals and/or preheat level settings. Scenes may be replayed using either the front panel controls or Preset control inputs.

Press ✓.

↖/↗ to select the attribute to change and press ✓.

#### 31 REPLAY?

Select a previously recorded scene or programme chase to output.

#### 311 GO [ n]

↖/↗ to select a scene or chase and press ✓. ⇒ OUTPUT OK

#### 32 RECORD?

Save the current dimmer output to one of the 8 scene memories or access wall plate programming mode.

#### 321 GET SCENE [n]

↖/↗ to select scene numbers 1-8 or R (for remote programming, see page 5).

Press ✓ to capture current dimmer output. ⇒ STORED OK

#### 33 DMX FAIL?

The following options are selectable in the event that the DMX input to the dimmer fails or is removed. This is only applicable when DMX is a selected input source.

#### 331 [     ]

Default = LAST HELD

Choose from:

**LAST HELD** the last signal received is held in the outputs.

**GO NO DMX** the NO DMX SCN scene is output.

**SCENE 8** a user-programmed scene is output.

**GO ANALOG** the Paradime looks for an analogue input signal.

**SCN8+WP** the Paradime outputs scene 8. Control from any connected WP6 wall plate is also active.

**ALL OFF** all channels go to 0 output.

↖/↗ to desired option and press ✓ to store. ⇒ STORED OK

#### 34 MAP INPUTS?

Pins 1-6 of the analogue input connector can be used to access the Preset inputs and may be mapped to any of the stored scenes 1-8 and/or programmed chase/speeds 10-99.

#### 341 CHANNEL [n]

↖/↗ to select one of the six available presets and press ✓.

#### 3411 DO [     ]

↖/↗ to select one of the available scenes or chase programs chases for this channel number and press ✓.

#### 35 FADE TIMES?

In a similar way to individual channels, the scenes 1-8 may be set to automatically fade in/out over a set period of time. This is useful for 'seamless' level changes in some architectural lighting applications. Fades between scenes are 'dipless'. NOTE: In this menu the fade time is applied to the complete scene and not an individual channel as in menu 24.

#### 351 SCENE [n]

↖/↗ to select scene and press ✓.

#### 3511 [00m 00s]

↖/↗ to set the desired fade time for the scene and press ✓. ⇒ STORED OK



## MENU SYSTEM AND USER OPTIONS - cont'd

### 36 NO DMX SCN?

A scene or chase program selected here will be output if the DMX fail option, menu 33, is set to 'Go No DMX', DMX is a selected input type and the DMX signal fails or is missing.

361 [            ]

↖/↗ to select scene or chase and press ✓. ⇒ STORED OK

### 4 SET SUPPLY?

Press the ✓ - the display will show

#### 41 SET PHASES ?

Press the ✓ - the display will show

411 ORDER [   ]

Default = [aut]

Pressing the up or down arrow keys will change the setting within the square brackets on the display.

Subsequent presses will display the different settings available, these are:-

[111]    Single phase

[123]    3 Phases connected in the order 1,2,3

[132]    3 Phases connected in the order 1,3,2

[aut]    Auto phase order detection

Change to the desired option and press ✓ to select and memorise the setting. ⇒ STORED OK

#### 42 SET FREQ?

Press ✓.

421 FREQ [auto]

Default = [auto]

↖/↗ to select [50Hz], [60Hz] or [auto].

Press ✓ to select and memorise the setting. ⇒ STORED OK

### 5 SET INPUTS?

You may select the input signal type used to control the dimmer from the following list. Where there is more than one input signal source selected, the highest level received by any channel will be used (HTP)

Press ✓.

51 [            ]

Default = DMX+Analog.

Choose from: DMX only, ANALOG only, DMX+ANALOG, WP6, WP9.

Menu Description	Functionality
DMX only	DMX input only active
Analog only	Analogue input only active
DMX+Analog	DMX and analogue inputs mixed on HTP basis
WP9+DMX	Six 0-10V inputs have control over each scene - any/all scenes can be mixed on an HTP basis
WP6 + DMX	Latching scene control input for use with 6-button panel. Mixed with DMX input on HTP basis
WP6 + CONT	WP6 swaps with DMX according to level of seventh channel.
DMX   Analog	Analogue output if no DMX.
WP6M	Level control of four scenes.



See page 5 for fuller explanations of of the various inputs.

↖/↗ to select option and press ✓ to store. ⇒ STORED OK

## MENU SYSTEM AND USER OPTIONS - cont'd

### 6 SET TEXT?

The text message 'LightProcessor Digital Dimmer' which scrolls through the display during normal operation may be edited to a message of your choice. The message may contain up to 40 alphanumeric characters. Note: The hardware link must be removed before you can make changes. If the menu is 'locked' (or if WP9 is the selected input option) the message NOT ALLOWED will be displayed .

Press ✓.

LightPro [ L ] ^v to change the character shown in the brackets[ ]

Press ✓ to move to the next character.

At the end of your message, using the v button select [END] then press ✓ to store the changes. ⇒ STORED OK

When editing an existing message, press ✓ repeatedly until the end of the message is reached before selecting [END] and storing the changes.

### 7 SET EXTRAS?

Press ✓.

#### 71 SET FAN PUFF

It is not normally necessary to alter this setting. In previous versions fan puff 'on was the default setting and in some circumstances where the noise of the fan puff was considered intrusive, it was possible to disable the fan puff, leaving the fan to run at a constant low speed during normal operation. This is now the default setting. In either case the overall operation of the thermal management system is not affected.

Press ✓.

#### 711 PUFF[OFF]

Default = OFF.

^v to set to ON or OFF and press ✓. ⇒ STORED OK

### 8 READ INFO?

The following information is available.

Press ✓.

^v to select the attribute to change.

#### 81 HOURS USED?

The number of complete hours the dimmer has been in operation.

Press ✓ to view.

811 [00000 HOURS]

#### 82 TEMPERATURE

Press ✓ to view.

821[ ] nnn°C

Choose from: MIN , MAX , NOW

^v to view option. When RESET is shown, press ✓ to reset the maximum and minimum readings.

#### 83 DMX LEVELS

View DMX input levels as 0-255

831 CH[n] = nnn

^v to scroll through each of the six dimmer channels - the current DMX input level is shown.

#### 84 ANA LEVELS

View Analogue input levels as 0-255

841 CH[n] = nnn

^v to scroll through each of the six dimmer channels - the current analogue input level is shown.

#### 85 SCENE LEVELS

View the output levels of each channel in each of the eight stored scenes.

Press ^ to scroll through each of the six channels in scene one followed by each of the channels in scene two etc. The data is shown in the form SCN[N]CH[N][nnn]. Press ✕ to go back to menu 8.



## MENU SYSTEM AND USER OPTIONS - cont'd

### 86 CLEAR ERROR

Used to clear error messages caused by conditions which require the dimmer to be examined before further use. Access to this function may be restricted to installers and is dealt with in separate installation instructions.

Press ✓ to clear any current error.

### 87 MENU ACCESS

861 [       ]

Choose from: UNLOCKED , LOCKED.

^v to select option and press ✓. ⇒ STORED OK

### 88 SET DEFAULTS?

Returns all software settings and features to the factory default values.

Press ✓. ⇒ STORED OK

### 89 READ SERIAL?

Displays the installed software version and electronic serial number.

Press ✓.

Display shows REV. NN S/nnnnn

### 8A READ QUEST?

Displays the quest number which summarises the current configuration of the Paradime. This may be used for remote diagnosis of status and for troubleshooting. Software is available for the interpretation of the Quest Number.

Press ✓.

Display shows [NNNNNNNNNNNNNNNN]. Default = 0100000000000000.

Press ✕ to return to menu 8.



## 9 TEST CHANNELS

Press ✓.

### 91 CH[n] ✓ =TEST

^v to select individual channels (or All option [A]).

Press ✓ once to switch channel(s) on 50%

Press ✓ again to switch channel(s) on 100%

Press ✓ again to switch channel(s) OFF.

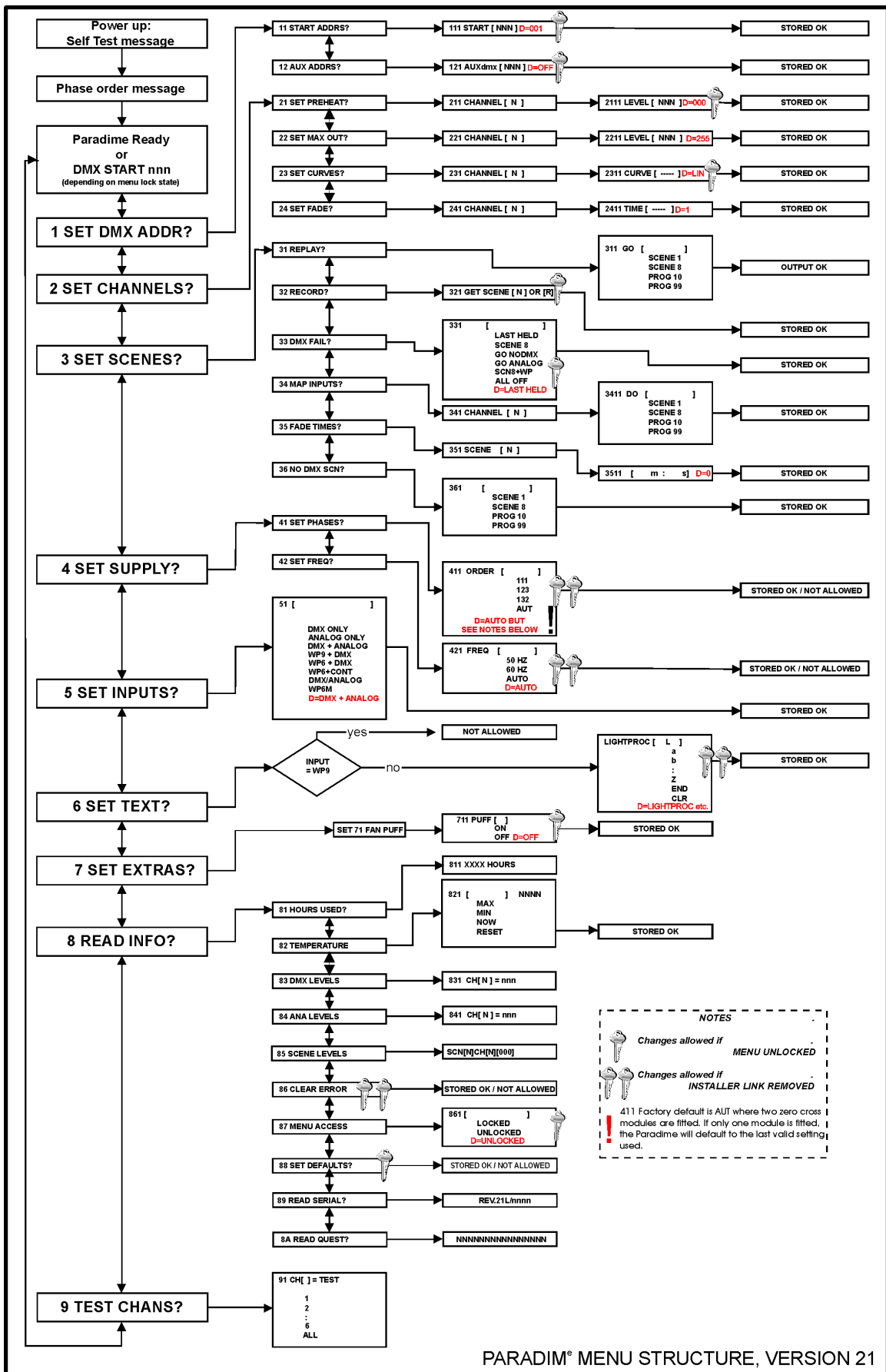

PARADIM® MENU STRUCTURE, VERSION 21

Fig. 19

## NOTES ON 1 x 63A MODEL5

The notes in this section refer specifically and exclusively to the 1 channel x 63A Paradime.

This model is available in rack-mount format only and takes up four rack units.

Both input and output are made via 63A Ceeform connectors.

The menu system used is largely that shown on page 11 of this manual but you should note the following differences.

Menu options 31, 32, 34, 35, 36, are not available

Menu 51 allows only DMX only, Analogue only and DMX+Analogue

A front panel manual control facility is provided, using a rotary control to vary the output level between zero and 100%. Because a standard 8-pin DIN plug typically has six channel control pins (and analogue outputs from desks are typically grouped in sixes), it is necessary to configure the analogue input of the single channel 63A Paradime to accept control commands from only one pin. The control channel is chosen, using a rotary control to select a channel in the range one to six: there is also an all-off setting. An analogue thru connector allows continuation of the analogue control cable to other dimmers where other channels can be selected. See Fig. 20 below.

Spare parts for this model are the same as for other Paradime models with the following exceptions.

Opto Module, Ref:XXXXXXXX

SCR, Ref:XXXXXXXXXXXX

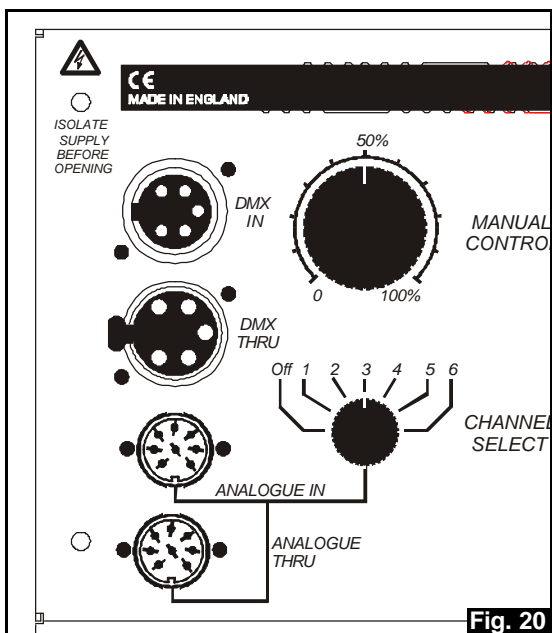

## MAINTENANCE

As with all commercial products of this type, it is the responsibility of the user/owner of the equipment to apply test and maintenance procedures to ensure compliance with local laws and regulations. Regular internal inspection by qualified personnel will ensure reliable operation. Accumulated dirt and dust should be removed carefully. There should be no loose cables within the unit. All plugable modules should be firmly seated in their sockets. Any cables/sockets showing signs of wear or damage should be replaced. Any internal installation wiring should be kept to a minimum and kept clear of the heatsink. The cooling fan is the only moving part; it has a normal lifespan of approximately five years. Rotate the fan manually to assess its state of health. Keep the fan and its grille free from dust and dirt. Do not use a high pressure pneumatic line for this purpose, as this may cause the fan to spin at high speed and damage the fan motor and electronics.

### PORTABLE APPLIANCE TESTING

This type of periodic testing should be carried out on all types of portable equipment in accordance with the policies set down by the operating company. The following describes three tests that may be applied.

All tests must be performed with the equipment DISCONNECTED from the mains power supply.

1. Continuity. This is a qualification test between the input live and neutral. This tests the internal circuitry and fusing to ensure that a valid circuit exists.
2. Earth Bond. This tests the continuity and capability of the earthing system to ensure (a) that a circuit exists and (b) that it is capable of handling large fault currents. The test must be performed between the main input connector's earthing point and the case of the dimmer. Any probe used must be sharp enough to break through the paint on the case. The test must be repeated on the earth pin of each output socket to ensure that the socket provides a proper earth for its load.
3. Insulation. This tests whether there is any fault within the product that could cause the case to become live. Tests must be applied to both the input terminals and the output terminals/sockets. Because triacs will be 'off' when the insulation test is performed, the internal circuitry and wiring after the triac will need to be connected in parallel with the mains input terminals. Therefore the insulation test must be performed with all accessible lives and neutrals paralleled together: each output socket must have its live and neutral connector shorted together, joined with all other outlets and finally joined with the shorted input phase and neutral terminals. This represents a single terminal to which a high voltage is applied with respect to the earth terminal. All circuit breakers must be 'on' for this test.

## SYSTEM MESSAGES

There are various messages that may be displayed. General status or information messages include:

<b>DMX Received OK</b>	DMX is selected and the unit is now receiving valid DMX data.
<b>DMX Absent</b>	DMX is selected but the unit is no longer receiving valid DMX.
<b>Invalid Start</b>	DMX is selected but incompatible data is being received.
<b>Output Scene 'n'</b>	Scene 'n' has been selected from the remote input.
<b>Output Prog 'n'</b>	Chase programme 'n' has been selected from the remote input.
<b>No Preset Chosen</b>	Remote has been selected as an input source but currently nothing is active.

Messages relating to critical faults and error conditions that may affect the operation of the unit include:

<b>Over Temperature</b>	<p>The dimmer has been operated outside the recommended parameters and has reached an unacceptable temperature. This may be due to changes in the ventilation arrangements, a dirty fan or similar and will require the unit to be inspected and reset by the installer or similar competent engineer.</p> <p>Over temperature errors occur for a reason. Deal with the problem before re-setting the unit.</p>
<b>Service Required</b>	This indicates that the last time the unit was used a critical fault occurred. The fault must be dealt with and then the unit must be re-set by the installer or similar competent engineer before it can be used again.
<b>Zero Cross Fail</b>	Zero cross module failure. Refer to installer. Module replacement may be necessary.
<b>IIC Error</b>	Temperature sensor failure. Refer to installer. Sensor replacement may be necessary.

Error messages must be cleared to allow the Paradime to continue operating. See the comments relating to menu 86 on page 10 of this manual and those relating to the Installer Hardware Lock on page VI of the installer instructions.



## SPECIFICATION

### Power Requirements

Voltage	230V AC nominal. (194-264V AC) Link selectable to 115V AC nominal. (100-120V)
Frequency	48-62Hz.

Three phase + neutral + earth  
Single phase + neutral + earth with links fitted (10A per channel models only)

### Dimming Capacity

Six channels of dimming per dimmer unit.

Maximum load:	10A models	10A per channel/60A total.
	16A models	16A per channel, 3-phase only 32A per phase. 96A total.
	20A models	20A per channel, 3-phase only 40A per phase. 120A total.
	25A models	25A per channel, 3-phase only 25A per phase. 75A total (3-channels).

Minimum load: All models 100W per channel

### Control Inputs

Analogue 0 to +10V, via 8-pin locking DIN.  
20kOhm input impedance

USITT DMX512 (1990), via 5-pin XLR.

### Output Connectors

Power output connectors are available covering a range of international standards.

Hardwired versions are also available with screw terminal connectors.

### Phantom Power Output

16V DC unregulated and current limited by 100mA self-resetting fuse.

### Physical Characteristics

Weight: between 11 and 14Kg., depending on model and rating.

Dimensions:

#### Rack models

Height: (depending on model) 2, 3 or 4 rack units.

Width: 19 inch rack mounting

Depth: 360mm. (excluding any output sockets)

**10Amp** hardwired, hardwired D/P.

Sockets:- 6 x Schuko, 6 x French, 6 x US

6 x Swiss, 6 x UK (15A), 6 x CEE17, Patchpack

12 x Schuko, 12 x French, 12 x UK (15A)

**16Amp** hardwired, hardwired D/P.

Sockets:- 6 x Schuko, 6 x French, 6 x CEE17,

12 x Schuko, 12 x French, Patchpack

**20Amp** hardwired. Sockets:- 6 x Japanese C-type

**25Amp** hardwired.

#### Wall models

Height: 455mm.

Width: 335mm.

Depth: 105mm.

**10Amp** hardwired, Sockets:- 12 x UK (15A)

**16Amp** hardwired

**Other versions may be available to special order.**

### Environment

Temperature	0-30°C
Relative humidity	0-90% non-condensing
Pollution	Degree 2
Protection Classification	IP30

### Conformance

All Paradimes are designed to meet CE regulations covered by:  
LVD (using EN60439 and EN60950)  
EMC (EN55014 and EN50082-1)

## SPARE PARTS AND ACCESSORIES

Description	Reference
Cable, 0.4m Patch	9223204001
Cable, 0.8m Patch	9223208001
Circuit Breaker, 10A	BREAKER/10
Circuit Breaker, 16A	BREAKER/16
Circuit Breaker, 20A	BREAKER/20
Circuit Breaker, 25A	BREAKER/25
Heatsink/Triac Clip	TRIAC/CLIP
EPROM, set of 2	PAREPROMS
Fan	FAN/12V/PS
Fuse, Electronics 230V, 20mm. 100mA, anti-surge	F100MA2AS
Fuse, Electronics 115V, 20mm. 200mA, anti-surge	F200MA2AS
Module, Opto	PAR/OPTO
Module, Phase Detect	PAR/ZERO
Module, Plug-in Control Input (Wallmount Models)	PARWALPLUG
Module, LCD Processor	PAR/SMT/8L
Service Plate - Blank	MPARADIM/B
Service Plate , Double 16-pin	PAR/D/HART
Service Plate, Double 19-pin	PAR/D/SOC
Service Plate, Single 16-pin	PAR/S/HART
Service Plate, Single 19-pin	PAR/S/SOC
Service Plate, Wieland hotpatch	PAR/HOT
Socket, 15A UK	S15AMPUK
Socket, CEE17	SCEEQP
Socket, Double French	SKAISEL501
Socket, Double Schuko	SSCHUKO
Switch, Front Panel	SCKS05S4
Transformer 12VA	T6VA/12/9V
Triac, 10A Paradime	T26-600
Triac, 16A Paradime	T4KWTRIAC
Triac, 20A, 25A Paradime	T5KWTRIAC
Front Cheek Set, 2U, incl. Screws	PAR2UFCSET
Rear Cheek Set, 2U, incl. Screws	PAR2URCSET
Front Cheek Set, 3U, incl. Screws	PAR3UFCSET
Rear Cheek Set, 3U, incl. Screws	PAR3URCSET
Front Cheek Set, 4U, incl. Screws	PAR4UFCSET
Rear Cheek Set, 4U, incl. Screws	PAR4URCSET
Front Cheek Screw	SM4X8PPS
Patchpack Panel Connector Inlet	9203190581 (Wieland)
Patchpack Panel Connector Outlet	9203290581 (Wieland)
DMX Driver Chip, 8-pin DIL	75176
Triac Connector, 3-way Spring-Loaded	C3WAYPCB/F
Temperature Sensor	DS1621
Single Phase Link Kit	1PHASLINKS
63A Input Terminal Connector	S60AMP2WAY
10/16A Output Terminal Connector	C2WAY/7102
20/25A Output Terminal Connector	PK8802
Earth Block	EARTH/PAR
32mm. Cable Strain Relief Gland	PARGLAND32
20mm, Cable Strain Relief Gland	PARGLAND20

**ALWAYS INSIST ON ORIGINAL SPARE PARTS BEING FITTED**

## **WARRANTY STATEMENT**

LightProcessor provides a warranty against manufacturing defects for all Products for a minimum period of twelve months from date of purchase, provided that the Products have not been subjected to any unauthorised modification or repair.

The liability of LightProcessor to its Customers for death or personal injury resulting from our negligence is unlimited. LightProcessor shall not be liable to the Customer by reason of any representation or any implied warranty, condition or other term or any duty at common law for any indirect, special or consequential loss or damage, costs, expenses, or other claims for compensation whatsoever which arise out of or in connection with the sale or supply of the Products or their use or resale by the Customer.

All items added to the Product by the Customer, its agents or customers, must be removed from the Product prior to return to LightProcessor. The return of the Product shall authorise LightProcessor to remove any such items. Time taken to remove them may be chargeable, even in the event that the repair is covered by this warranty. LightProcessor shall not be obliged to reconnect any such items before returning the Product. LightProcessor will not be under any liability in respect of such items.

The cost of shipping defective Product back to LightProcessor is borne by the Customer. The cost of shipping back to the Customer is borne by LightProcessor, subject to the repair being accepted as a warranty repair.

LightProcessor reserves the right either to repair or replace any defective Product.

Any unauthorised modification made to the product may invalidate this warranty and could affect the safe operation of the product.

## **WARRANTY REPAIRS PROCEDURE**

Prior to any Product being shipped for warranty repair or replacement the Customer must have applied for a "Warranty Authorisation Number". This can be obtained from the Sales Administration Manager at LightProcessor's Head Office.

LightProcessor will then issue a 'Warranty Fault Report' that must be completed in all respects by the Customer. Failure to complete the 'Warranty Fault Report' may cause delays in processing the repair of the Product.

The completed 'Warranty Fault Report' may either be Faxed, E-Mailed, Mailed or accompany the Product when it is returned

LightProcessor will advise the Customer within 1 working day of the receipt of the Product or the Warranty Fault Report, whichever is the later, whether or not it accepts that the Product is covered under Warranty.

Warranty Repairs will be completed within 2 working days, subject to spare parts being available, and will be returned to the Customer without delay.

Should a Product be returned for repair in damaged or non-original packaging, LightProcessor reserves the right to re-package the Product in its correct packaging and to charge a re-packing fee (max. £20).

## **NON-WARRANTY REPAIRS PROCEDURE**

Prior to any Product being shipped for repair the Customer must have applied for a "Repair Authorisation Number". These can be obtained from the Sales Administration Manager at LightProcessor's Head Office.

LightProcessor will then issue a 'Repair Fault Report' that must be completed in all respects by the Customer. Failure to complete the 'Repair Fault Report' may cause delays in processing the repair of the Product.

The completed 'Repair Fault Report' may either be Faxed, E-Mailed, Mailed or accompany the Product when it is returned

LightProcessor will advise the Customer within 5 working days of the receipt of the Product or the Repair Fault Report, whichever is the later, the Estimated Cost of Repair excluding labour and carriage, but including a minimum charge for the inspection of the product, being ¼hr. labour .

Non-Warranty Repairs will be completed within 10 working days of receipt by the Customer of the Repair Cost Estimate, subject to spare parts being available, and will be returned to the Customer without delay.

Should a Product be returned for repair in damaged or non-original packaging, LightProcessor reserves the right to re-package the Product in its correct packaging and to charge a re-packing fee (max. £20).

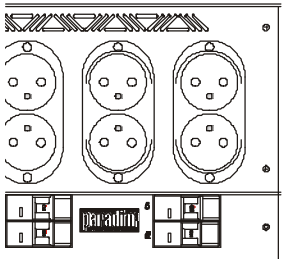
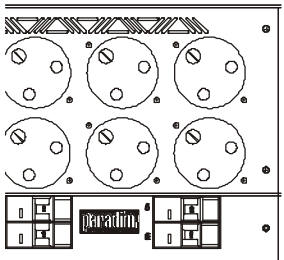
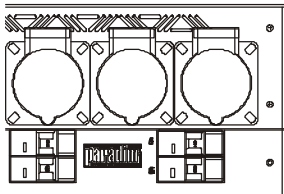
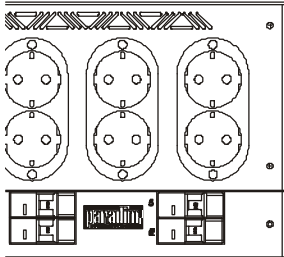
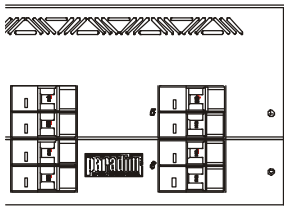

### Also available from LightProcessor

- QCommander automated lighting control system
  - QCommander 256 (standard and extended models)
  - QCommander 512 (standard and extended models)
  - Input Extender fader panel
  - Replica memory store and playback unit
- DMX Tools
  - DMuX demultiplexer
  - Store memory store and playback unit
  - Merge DMX merge and multiplexer
  - Buffer DMX splitter, isolator and booster
- Dimension installation dimming range
- Analogue and DMX 2-preset desks
  - Q12
  - Q24
- Analogue and DMX 1-preset desks
  - Zip 6
  - Zip 12
  - Zip 18



[www.lightprocessor.co.uk](http://www.lightprocessor.co.uk)  
[info@lightprocessor.co.uk](mailto:info@lightprocessor.co.uk)

Made in the United Kingdom

Note the serial numbers of the Paradimes in this installation and quote them when seeking help.